

Designation		Dimensions						Dimensions for detailing			
	G kg/m	h mm	b mm	t <sub>w</sub> mm	t <sub>f</sub> mm	r <sub>1</sub> mm	r <sub>2</sub> mm	A mm <sup>2</sup> x10 <sup>2</sup>	d mm	h <sub>i</sub> mm	u ξ = 8%
UPN 20 x 10 x 3	0.89	20	10	3	3.5	3.5	2.5	1.11	6.28	-	5.0
UPN 30 x 15 x 4	1.78	30	15	4	4.5	4.5	2.5	2.23	12.10	-	7.5
UPN 30 x 33 x 5	4.37	30	33	5	7	7	3	5.46	0.46	-	16.5
UPN 40 x 20 x 3	1.83	40	20	3	3.3	3.3	3	2.29	25.28	-	10.0
UPN 40 x 20 x 4	2.43	40	20	4	4.5	4.5	3	3.04	21.40	-	10.0
UPN 40 x 35 x 5	4.98	40	35	5	7	7	3	6.23	10.18	-	17.5
UPN 50 x 25 x 5	3.90	50	25	5	6	5	3.5	4.87	27.10	-	12.5
UPN 50	5.60	50	38	5	7	7	3.5	7.00	19.76	-	19.0
UPN 60 x 30 x 6	5.16	60	30	6	6	6	3	6.45	34.92	-	15.0
UPN 65	7.11	65	42	5.5	7.5	7.5	4	8.88	32.46	-	21.0
UPN 80	8.68	80	45	6	8	8	4	10.85	45.30	-	22.5
UPN 80*	8.85	80	45	6	8	2	< 1	11.06	60.00	64.00	
UPN 100	10.61	100	50	6	8.5	8.5	4.5	13.26	62.72	-	25.0
UPN 100*	10.80	100	50	6	8.5	2	< 1	13.50	79.00	83.00	
UPN 120	13.40	120	55	7	9	9	4.5	16.75	80.42	-	27.5
UPN 120*	13.65	120	55	7	9	2	< 1	17.06	98.00	102.00	
UPN 140	16.08	140	60	7	10	10	5	20.10	95.95	-	30.0
UPN 140*	16.33	140	60	7	10	2	< 1	20.42	116.00	120.00	
UPN 160	18.96	160	65	7.5	10.5	10.5	5.5	23.70	113.51	-	32.5
UPN 160*	19.27	160	65	7.5	10.5	2	< 1	24.09	135.00	139.00	

# UPN

# گروپی چیوه



## Chiwa Group

For Steel & Fence

Iraq - Kurdistan - Erbil  
 E-mail: [aram@chiwagroup.com](mailto:aram@chiwagroup.com)  
 Tel: 066 229 4058 / 0750 445 8512  
[www.chiwagroup.com](http://www.chiwagroup.com)

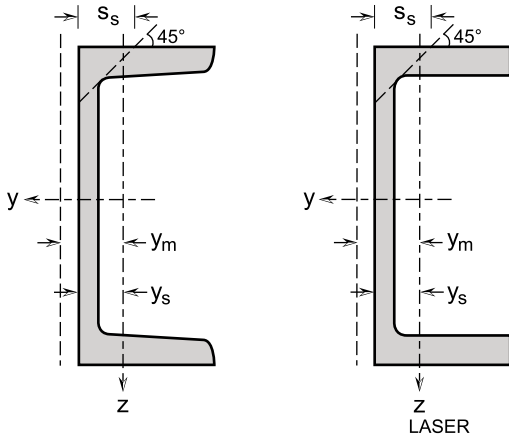

Designation	Strong axis y-y					Weak axis z-z								
	$I_y$ mm <sup>4</sup> x10 <sup>4</sup>	$W_{el.y}$ mm <sup>3</sup> x10 <sup>3</sup>	$W_{pl.y}$ mm <sup>3</sup> x10 <sup>3</sup>	$i_y$ mm x10	$A_{vz}$ mm <sup>2</sup> x10 <sup>2</sup>	$I_z$ mm <sup>4</sup> x10 <sup>4</sup>	$W_{el.z}$ mm <sup>3</sup> x10 <sup>3</sup>	$W_{pl.z}$ mm <sup>3</sup> x10 <sup>3</sup>	$i_z$ mm x10	$S_s$ mm	$I_t$ mm <sup>4</sup> x10 <sup>4</sup>	$I_w$ mm <sup>6</sup> x10 <sup>9</sup>	$y_s$ mm x10	$y_m$ mm x10
UPN 20 x 10 x 3	0.54	0.54	0.70	0.70	0.76	0.08	0.12	0.23	0.26	8.37	0.04	0.00	0.34	0.51
UPN 30 x 15 x 4	2.53	1.69	2.16	1.07	1.46	0.36	0.36	0.64	0.40	11.04	0.13	0.00	0.49	0.77
UPN 30 x 33 x 5	6.40	4.27	5.56	1.08	2.17	4.81	2.37	4.08	0.94	16.80	1.01	0.01	1.27	2.17
UPN 40 x 20 x 3	5.13	2.56	3.15	1.50	1.30	0.64	0.44	0.76	0.53	8.88	0.08	0.00	0.53	1.10
UPN 40 x 20 x 4	6.53	3.27	4.08	1.47	1.82	0.89	0.63	1.08	0.54	11.39	0.19	0.00	0.59	1.08
UPN 40 x 35 x 5	14.10	7.05	8.81	1.50	2.66	6.25	2.79	4.62	1.00	16.94	1.07	0.01	1.26	2.29
UPN 50 x 25 x 5	16.34	6.54	8.22	1.83	2.77	2.30	1.33	2.84	0.69	14.33	0.54	0.01	0.77	1.40
UPN 50	26.24	10.50	12.83	1.94	3.01	8.37	3.36	6.78	1.09	17.15	1.17	0.03	1.31	2.48
UPN 60 x 30 x 6	30.66	10.22	12.85	2.18	3.93	4.06	1.89	4.19	0.79	16.00	0.77	0.02	0.85	1.57
UPN 65	56.78	17.47	21.15	2.53	4.12	12.79	4.50	9.38	1.20	18.59	1.62	0.08	1.36	2.65
UPN 80	104.41	26.10	31.52	3.10	5.41	17.68	5.67	11.90	1.28	19.96	2.16	0.18	1.38	2.74
UPN 80*	106.97	26.74	32.17	3.11	4.50	21.80	7.44	8.69	1.40	15.18	2.09	0.16	1.57	2.97
UPN 100	202.41	40.48	48.40	3.91	6.71	26.49	7.51	16.20	1.41	21.04	2.84	0.41	1.47	3.02
UPN 100*	207.30	41.46	49.36	3.92	5.68	33.07	9.98	11.38	1.57	15.68	2.71	0.37	1.69	3.27
UPN 120	357.25	59.54	71.81	4.62	9.10	38.85	9.77	21.20	1.52	22.98	4.03	0.90	1.52	3.15
UPN 120*	367.96	61.33	73.33	4.64	7.97	49.15	13.08	14.88	1.70	17.18	3.99	0.77	1.74	3.38
UPN 140	595.97	85.14	101.65	5.45	10.80	56.57	13.05	28.30	1.68	24.78	5.67	1.80	1.66	3.48
UPN 140*	609.41	87.06	103.40	5.46	9.32	71.05	17.36	19.48	1.87	18.18	5.46	1.52	1.91	3.76
UPN 160	909.37	113.67	135.98	6.19	13.04	76.62	16.09	35.20	1.80	26.29	7.30	3.26	1.74	3.69
UPN 160*	932.63	116.58	138.50	6.22	11.44	97.42	21.67	24.15	2.01	19.18	7.09	2.69	2.00	3.98

# UPN

# گروپی چیوه



## Chiwa Group

For Steel & Fence

Iraq - Kurdistan - Erbil  
 E-mail: [aram@chiwagroup.com](mailto:aram@chiwagroup.com)  
 Tel: 066 229 4058 / 0750 445 8512  
[www.chiwagroup.com](http://www.chiwagroup.com)

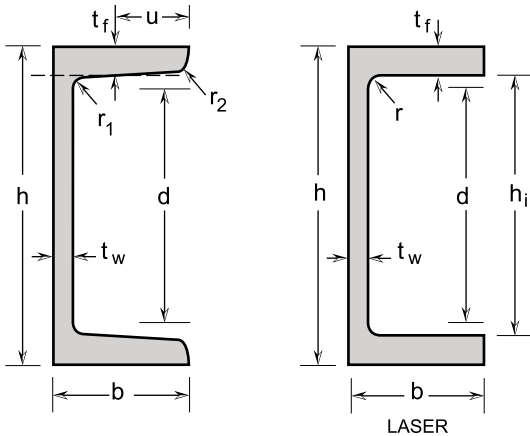

Designation		Dimensions						Dimensions for detailing			
	G kg/m	h mm	b mm	t <sub>w</sub> mm	t <sub>f</sub> mm	r <sub>1</sub> mm	r <sub>2</sub> mm	A mm <sup>2</sup> x10 <sup>2</sup>	d mm	h <sub>i</sub> mm	u ξ = 8%
UPN 180	22.09	180	70	8	11	11	5.5	27.61	131.07	-	35.0
UPN 180*	22.44	180	70	8	11	2	< 1	28.06	154.00	158.00	
UPN 200 <sup>+</sup>	25.84	200	75	8.5	11.5	2	< 1	32.31	173.00	177.00	
UPN 220 <sup>+</sup>	30.05	220	80	9	12.5	2	< 1	37.57	191.00	195.00	
UPN 240 <sup>+</sup>	33.96	240	85	9.5	13	2	< 1	42.45	210.00	214.00	
UPN 260 <sup>+</sup>	38.73	260	90	10	14	2	< 1	48.42	228.00	232.00	
UPN 280 <sup>+</sup>	42.81	280	95	10	15	2	< 1	53.52	246.00	250.00	
UPN 300 <sup>+</sup>	47.05	300	100	10	16	2	< 1	58.82	264.00	268.00	
UPN 320 <sup>+</sup>	59.93	320	100	14	17.5	2	< 1	74.92	281.00	285.00	
UPN 350 <sup>+</sup>	61.23	350	100	14	16	2	< 1	76.54	314.00	318.00	
UPN 380 <sup>+</sup>	63.71	380	102	13.5	16	2	< 1	79.64	344.00	348.00	
UPN 400 <sup>+</sup>	72.46	400	110	14	18	2	< 1	90.58	360.00	364.00	

# UPN

# گروپی چیوه



## Chiwa Group

For Steel & Fence

Iraq - Kurdistan - Erbil  
 E-mail: [aram@chiwagroup.com](mailto:aram@chiwagroup.com)  
 Tel: 066 229 4058 / 0750 445 8512  
[www.chiwagroup.com](http://www.chiwagroup.com)

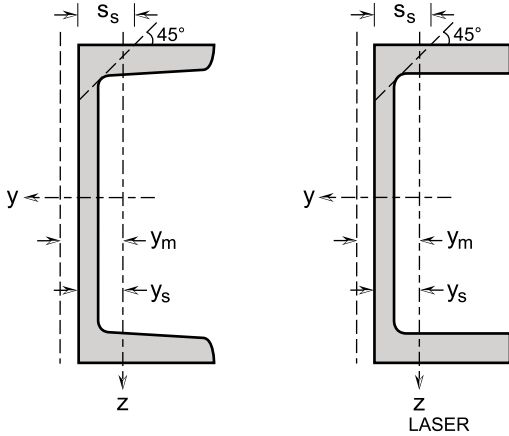

Designation	Strong axis y-y					Weak axis z-z								
	$I_y$ mm <sup>4</sup> x10 <sup>4</sup>	$W_{el.y}$ mm <sup>3</sup> x10 <sup>3</sup>	$W_{pl.y}$ mm <sup>3</sup> x10 <sup>3</sup>	$i_y$ mm x10	$A_{vz}$ mm <sup>2</sup> x10 <sup>2</sup>	$I_z$ mm <sup>4</sup> x10 <sup>4</sup>	$W_{el.z}$ mm <sup>3</sup> x10 <sup>3</sup>	$W_{pl.z}$ mm <sup>3</sup> x10 <sup>3</sup>	$i_z$ mm x10	$S_s$ mm	$I_t$ mm <sup>4</sup> x10 <sup>4</sup>	$I_w$ mm <sup>6</sup> x10 <sup>9</sup>	$y_s$ mm x10	$y_m$ mm x10
UPN 180	1329.45	147.72	177.07	6.94	15.51	101.80	19.65	42.90	1.92	27.80	9.27	5.57	1.82	3.90
UPN 180*	1365.17	151.69	180.33	6.98	13.76	130.28	26.60	29.49	2.15	20.18	9.06	4.49	2.10	4.20
UPN 200*														
UPN 200+	1928.35	192.83	229.46	7.73	16.27	170.62	32.20	35.56	2.30	21.18	11.42	7.18	2.20	4.42
UPN 220*	2713.15	246.65	293.39	8.50	18.94	225.67	39.87	43.97	2.45	22.68	15.32	11.48	2.34	4.71
UPN 240*	3627.90	302.32	359.97	9.24	21.84	285.51	47.12	51.81	2.59	23.68	18.78	17.14	2.441	4.93
UPN 260*	4859.51	373.81	444.92	10.02	24.90	365.32	56.92	62.52	2.75	25.18	24.36	25.73	2.582	5.22
UPN 280*	6313.62	450.97	534.30	10.86	26.82	457.00	67.84	73.96	2.92	26.18	29.60	37.63	2.763	5.63
UPN 300*	8066.44	537.76	634.42	11.71	28.74	564.28	80.02	86.72	3.10	27.18	35.77	53.77	2.948	6.05
UPN 320*	10719.93	670.00	814.15	11.96	42.72	642.94	88.18	101.49	2.93	32.68	62.98	66.72	2.709	5.23
UPN 350*	12687.32	724.99	888.88	12.88	47.10	618.19	82.40	95.61	2.84	31.18	58.09	74.37	2.50	4.83
UPN 380*	15565.03	819.21	1003.37	13.98	49.48	667.24	86.53	99.11	2.89	30.68	57.75	93.74	2.489	4.90
UPN 400*	20089.49	1004.47	1220.72	14.89	53.86	921.06	112.31	126.76	3.19	33.18	77.02	145.67	2.80	5.56